

# BIS RapidRail® T and X-Connector

to make BIS RapidRail® fabrications

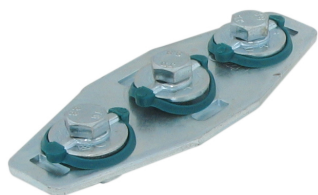

658 4 091



658 4 090

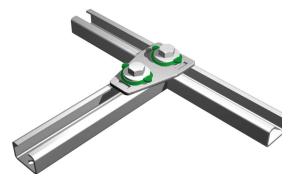

658 4 090

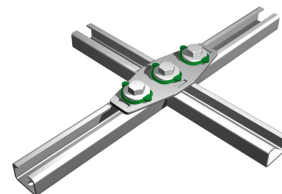

658 4 091



RAL-GZ 655/D  
Cert.Nr. 2012-08

## Features and benefits

- connector with pre-assembled BIS RapidRail® Slide nut(s)
- to make rail fabrications
- suitable for WM0, 1, 15, 2, 30, 35
- ready-to-use pre-assembled for a quick fixing, and retains assembly in place before final tightening
- material: metal parts made of steel 1.0332; spring(s) made of POM (polyoxymethylene), green
- zinc plated

Part No.	Type	For Rail	T (Nm)	Fa,x (N)	RAL	Pack 1
658 4 090	T	WM0 - 35	15	345	RAL <sup>1</sup>	25
658 4 091	X	WM0 - 35	15	345	RAL <sup>1</sup>	25

RAL<sup>1</sup> = tested, certified and externally monitored according to RAL-GZ 655/D in combination with Rail WM1, 2, 15 and 30.

For detailed technical information about our RAL marked products, please see the RAL datasheet in our webcatalogue: [www.walraven.com/gb/en/catalogue/](http://www.walraven.com/gb/en/catalogue/).

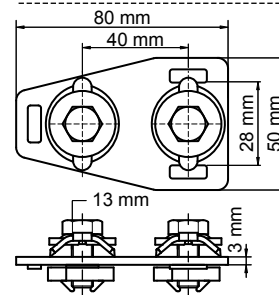

658 4 090

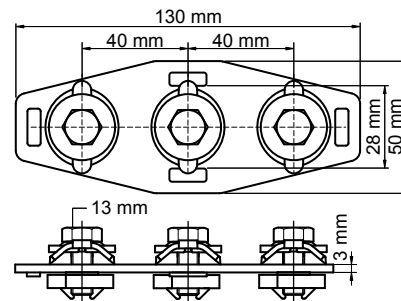

658 4 091

## Complementary

BIS RapidRail® Fixing Rail