

BIS Corner Bracket

to make BIS RapidRail® fabrications

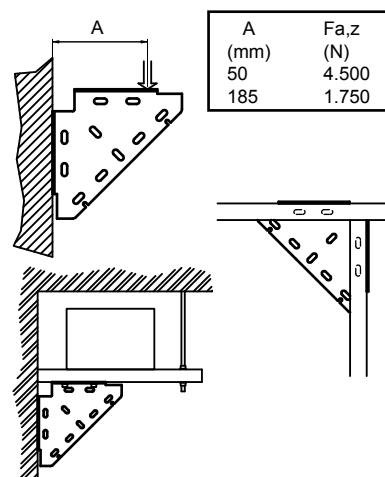

Features and benefits

- one-part support
- for fixing support under, top or on side of a cantilever arm
- also used to strengthen rail constructions
- suitable for WM0, 1, 15, 2, 30
- material: steel
- zinc plated

Part No.	For Rail	Pack 1
660 3 010	WM0 - 30	10

Corner Bracket for WM35 Rail? See Part No. 660 3 020 (page I 10 25).

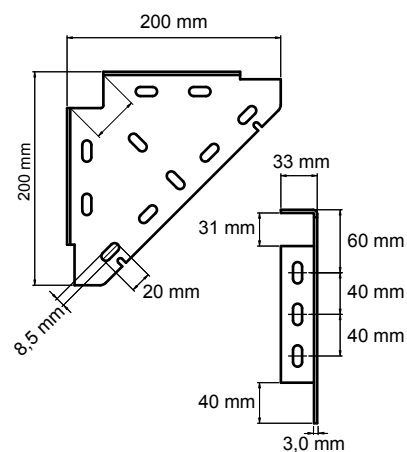

Alternative

BIS Rail Junction Angle Bracket (zp)

Complementary

BIS RapidRail® Fixing Rail